

EPSON RS-Series Robots

EPSON®
EXCEED YOUR VISION

High Performance SCARA Plus

- New, Unique Work Space Design
- Industry Leading Work Envelope Usage
- Arm Lengths 350 and 550mm
- Superior Cycle Throughput
- Zero Footprint Robot
- Extremely Flexible for Cell or Line Assembly
- ISO 3 Clean & ESD Options
- Fully Integrated Options including:
Vision Guidance, .Net Connectivity, EtherNet/IP,
DeviceNet, Profibus, Expansion I/O and more



Industry Leading Work Space Design

EPSON RS-Series robots are the most unique and flexible SCARAs available in the market today. Exclusive to the RS-Series robots is our new work space design which maximizes work envelope usage. By designing the arm structure so that Joint 2 can maneuver under Joint 1, RS-Series robots utilize the entire workspace underneath the arm. As a result, there is no lost space in the center of the work envelope. No other robot vendor offers a 350mm SCARA arm which can work on pallets as large as 494mm x 494mm. A pallet size this large would normally require a SCARA arm which is almost double the size. Imagine now being able to use a 350mm arm for applications that used to require a much larger 750mm arm – What a great saving of valuable floor space!

RS-Series are literally zero footprint robots. They are capable of easy integration into compact assembly cells. The unique work space design of RS-Series robots improves cycle time vs. other “old” SCARA designs - With the ability to maneuver back under itself for the shortest movements possible instead of having to move around itself, EPSON RS-Series robots deliver superior cycle rates. This means more parts processed in less time, while using a fraction of floor space which results in more profits for our customers.

All these exclusive features make the EPSON RS-Series robots the most versatile and inimitable SCARAs available in the market today. Enjoy all the benefits of a typical SCARA robot plus more!



The Best Just Got Better

EPSON RS-Series Robots

New, Unique Work Space Design



With a new innovative arm structure the RS-Series robots utilize the entire workspace underneath the arm, defeating the "old" SCARA design limitations of lost space in the center of the work envelope.

Zero Footprint Robot

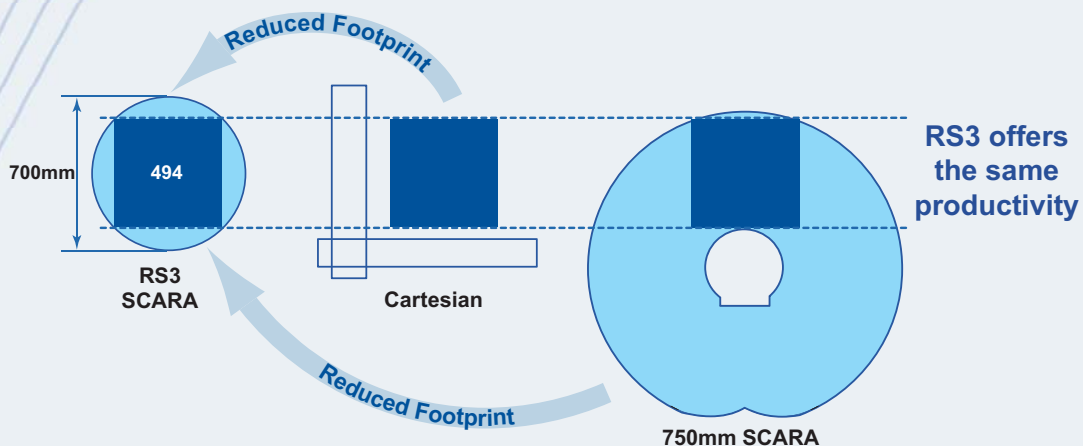

With the ceiling mount design and the 100% workspace utilization, RS-Series robots are a great alternative to cartesian, gantry and typical SCARA robots because they literally have a zero footprint - saving you valuable floor space.

Superior Cycle Throughput

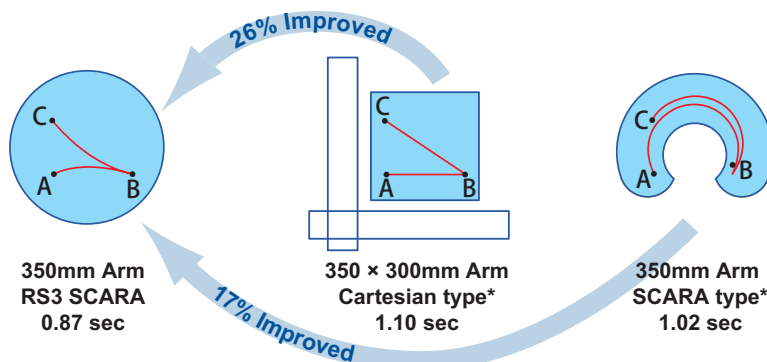

RS-Series robots maneuver under themselves for the shortest movements possible, delivering superior cycle rates.

* Current EPSON Robots

High Performance SCARA Plus

Optimized Workcell Design Examples

Stand Alone Cell Design

The unique work envelope of EPSON RS-Series robots allow for unprecedented design flexibility with over 360 degrees of axis rotation for omni directional access. This makes RS-Series robots perfect for process heavy applications where large quantities of parts are presented to process or testing stations.

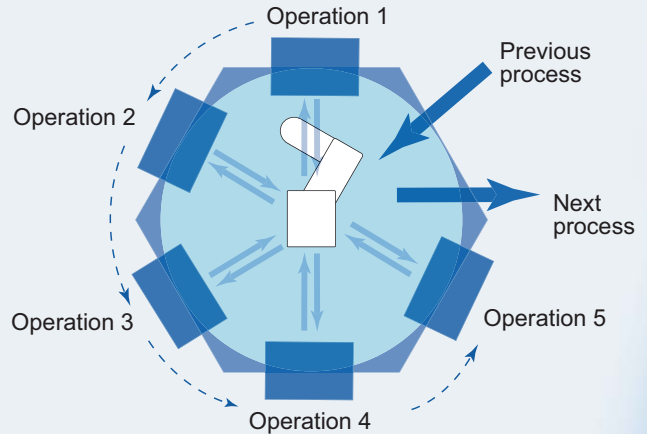

Assembly Line Design

EPSON RS-Series robots are capable of easy integration into extremely compact line design layouts due to the unique workspace design, zero footprint and ceiling mount configuration.

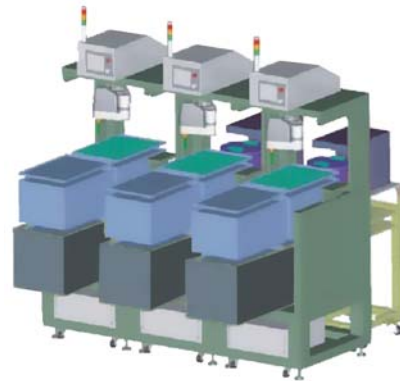

Multiple Pallets within Work Envelope

The new work space design of RS-Series robots allows for multiple pallets to be placed close together, maximizing the use of valuable floor space while also reducing cycle times.

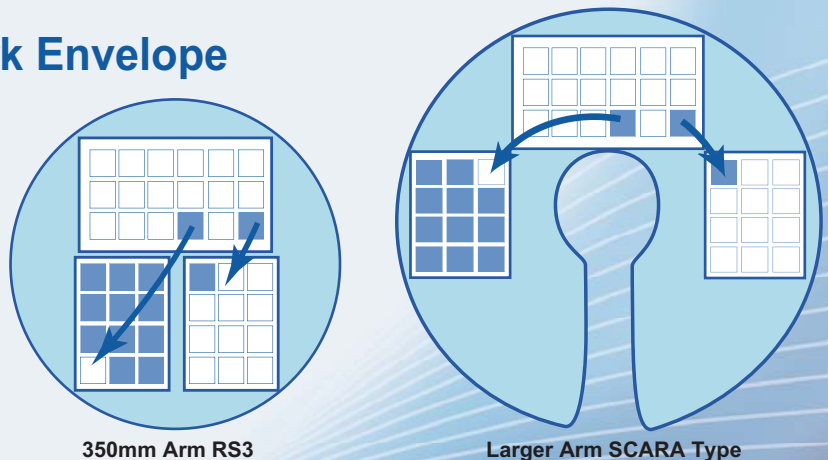

350mm Arm RS3

Larger Arm SCARA Type

RS-Series Specifications

EPSON ROBOT MODEL			RS3-351	RS4-551
Arm Length (mm)		Horiz. (J1 + J2)	175 + 175 = 350	275 + 275 = 550
Payload (kg)		Max. / Rated	3 / 1	4 / 1
Repeatability	mm	J1 + J2	+/-0.010	+/-0.015
		J3		+/-0.01
	deg	J4		+/-0.01
Cycle Time w/ 1kg (sec)			0.339	0.39
Max. Operating Speed	mm/sec	J1 + J2	6,237	7,400
		J3		1,100
	deg/sec	J4		2,600
Motor Wattage (W)			400 / 200 / 150 / 100	400 / 400 / 150 / 100
Insertion Force			150N	
U inertia	kg·m ²	Max. / Rated	0.05 / 0.005	
Axis Motion Range	Ceiling Mount	J1 (deg)	+/-225	
		J2 (deg)	+/-225	
		J3 (mm)	130*1 (100)*2	
		J4 (deg)	+/-720	
User Lines	Electric		15 lines	
	Air		ø4 x 1, ø6 x 2	
Z Axis Diameter (mm)			ø16	
Mounting Hole			120 x 120 x 120 (6-M6 @ 2 x 3)	
Weight (kg)			17	20
Environmental	Temperature		5 - 40 deg C	
	Humidity		10 - 80% (non condensing)	
Optional Configurations			ISO 3 Clean & ESD	
Robot Cables (Meters)			3M (standard) / 5M (optional) / 10M (optional)	
Available Controllers			Micro PowerDrive RC180 PC Based Controller RC620+	

*1 Standard configuration

*2 Clean & ESD configuration

EPSON Robots

18300 Central Avenue
Carson, CA 90746

Tel: +1 (562) 290-5910
Fax: +1 (562) 290-5999

E-mail: info@robots.epson.com
Web: robots.epson.com

EPSON reserves the right to make changes in specification at any time and without notice. The information furnished in this document is believed to be accurate and reliable. However, no guarantees are made. For the latest information, check our website at: www.robots.epson.com. Windows, Windows XP™, Windows Vista™ and Microsoft are trademarks of Microsoft Corporation. EPSON RC+ and SPEL+ are trademarks of SEIKO EPSON CORPORATION.
Rev: EPSONRS-Series

Available
with 2 Different
Controllers



**Micro PowerDrive
RC180**



**PC Based Controller
RC620+**



RS3-351



RS4-551